

You will need to print out this page, to complete the exercise. Click on the links, where they appear on this sheet, for guidance and samples.

PRESENTING IDEAS - THUMBNAIL SKETCHING

EXPLANATION

THUMBNAIL SKETCHES ARE SIMPLE OUTLINE DRAWINGS OF INITIAL IDEAS. THEY CAN BE LABELLED AND INCLUDE BRIEF NOTES. LIMITED COLOUR IS SOMETIMES APPLIED. THE SKETCHES ARE DRAWN QUICKLY, WITH A PENCIL, PEN, FELT PEN OR ANY MEDIA THAT THE DESIGNER FEELS COMFORTABLE USING.

What you need to do:



THE THUMBNAIL SKETCHES TO THE LEFT OF THIS PAGE, ARE FOR THE DESIGN OF AN UNUSUAL MP3 STATION. IN DIAGRAM 1, THE BASIC SHAPE IS DRAWN. OVER THE NEXT THREE STAGES LEGS ARE ADDED AND THE OVERALL SHAPE OF THE SPEAKERS IS DEVELOPED. NOTES COULD BE ADDED, BUT IN THIS CASE, THE DESIGNER HAS LIMITED THE IDEAS TO JUST THUMBNAIL SKETCHES. **YOU ARE TO DRAW FOUR MORE IDEAS FOR AN MP3 PLAYER, AS THUMBNAIL SKETCHES. USE THE LINK FOR GUIDANCE.**

SAMPLE THUMBNAIL SKETCHES

1. BASIC DESIGN

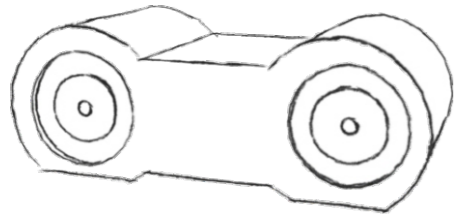

2. LEGS ADDED

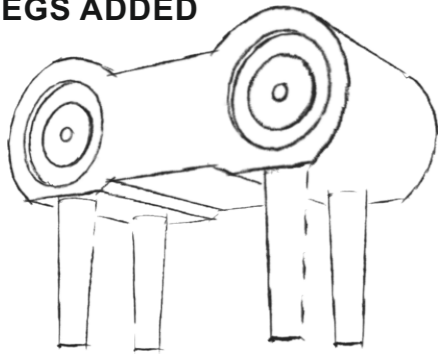

3. LEGS ON LEFT SHORTENED

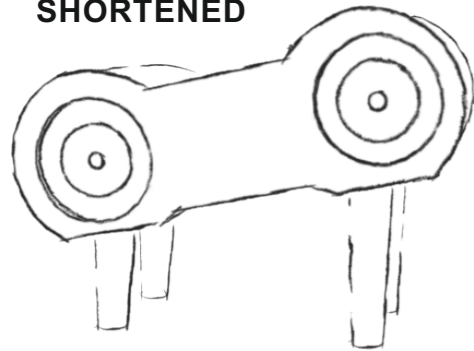

4. LEFTHAND SPEAKER ENLARGED

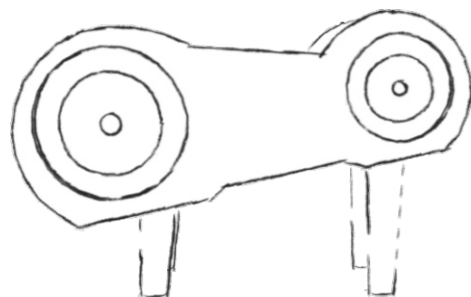

YOUR IDEAS / THUMBNAIL SKETCHES

You will need to print out this page, to complete the exercise. Click on the links, where they appear on this sheet, for guidance and samples.

PRESENTING IDEAS - THUMBNAIL SKETCHING

WORLD ASSOCIATION OF TECHNOLOGY TEACHERS <https://www.facebook.com/groups/254963448192823/> www.technologystudent.com © 2020 V.Ryan © 2020

EXPLANATION

THUMBNAIL SKETCHES CAN BE USED TO DEVELOP AN IDEA, ALMOST TO THE FINAL VERSION. THE SAMPLE MP3 PLAYER FROM THE PREVIOUS PAGE / SLIDE, HAS BEEN DEVELOPED BELOW. SKETCH 5 SHOWS THE IDEA BEING DEVELOPED, BY ADDING IMAGES (e.g. THE HANDLE AND WHEELS). SKETCH 6 SHOWS THE IDEA BEING IMPROVED BY THE ADDITION OF COLOUR / SHADE AND DETAIL.

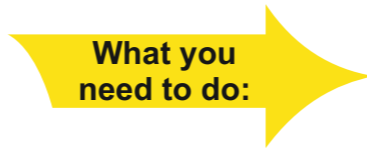

SELECT YOUR BEST IDEA FROM YOUR SKETCHES ON THE PREVIOUS PAGE / SLIDE. DEVELOP YOUR SELECTED IDEA, USING THE TECHNIQUES SHOWN BY THE SAMPLES ON THIS PAGE. **USE THE LINK OPPOSITE FOR GUIDANCE.**



YOUR IDEAS / THUMBNAIL SKETCHES

SAMPLE THUMBNAIL SKETCHES

5. HANDLE AND CASTERS ADDED - FOR TRANSPORT

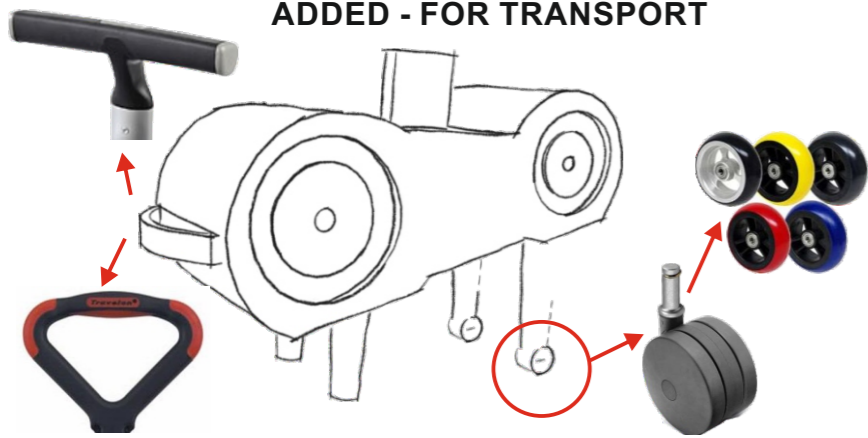

6. HANDLE AND CASTERS ADDED - FOR TRANSPORT

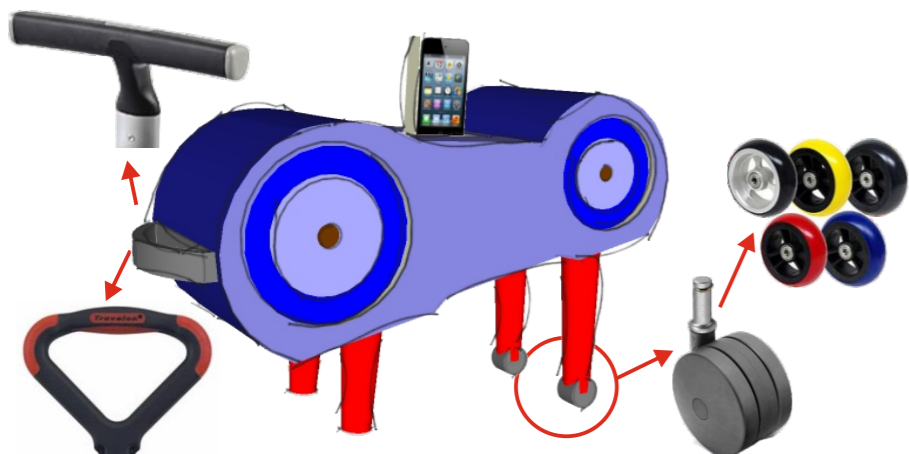

LINKS FOR SHADING TECHNIQUES



You will need to print out this page, to complete the exercise. Click on the links, where they appear on this sheet, for guidance and samples.

EXTENDED EXERCISE - THUMBNAIL SKETCHING - PUBLIC SEATING

C

WORLD ASSOCIATION OF TECHNOLOGY TEACHERS <https://www.facebook.com/groups/254963448192823/> www.technologystudent.com © 2020 V.Ryan © 2020

A MANUFACTURER OF SEATING SYSTEMS, HAS ASKED YOU TO PRODUCE A RANGE OF DESIGNS, FOR SEATING SUITABLE FOR ADULTS AND YOUNG CHILDREN, AIMED AT PUBLIC AREAS. STUDY THE EXAMPLES OF PUBLIC SEATING SEEN BELOW.

What you need to do:

ON THE NEXT PAGE / SLIDE - PRODUCE FOUR IDEAS FOR THE SEATING SYSTEM. CLEARLY INDICATE HOW EACH IS SUITABLE FOR BOTH ADULTS AND YOUNG CHILDREN. YOUR DESIGNS SHOULD BE CREATIVE AND INNOVATIVE. YOUR DESIGNS SHOULD BE THUMBNAIL SKETCHES AND INCLUDE NOTES, COLOUR / SHADE.

PUBLIC SEATING 'A'



What do you think of this seating system?

PUBLIC SEATING 'C'



What do you think of this seating system?

PUBLIC SEATING 'B'



What do you think of this seating system?

PUBLIC SEATING 'D'

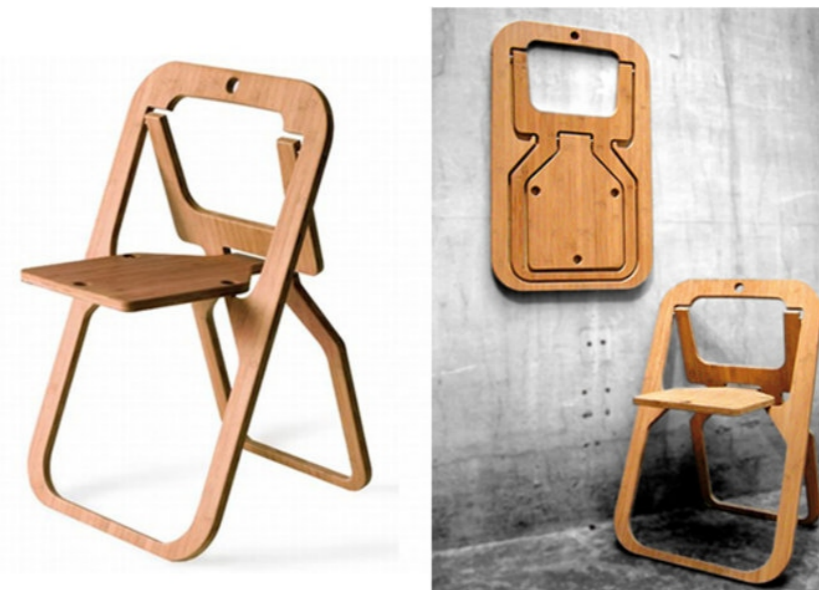

What do you think of this seating system?

You will need to print out this page, to complete the exercise. Click on the links, where they appear on this sheet, for guidance and samples.

YOUR IDEAS - THUMBNAIL SKETCHING - PUBLIC SEATING

WORLD ASSOCIATION OF TECHNOLOGY TEACHERS <https://www.facebook.com/groups/254963448192823/> www.technologystudent.com © 2020 V.Ryan © 2020

What you need to do:

DRAW YOUR THUMBNAIL SKETCHES ON THIS SHEET. USE ADDITIONAL SLIDES / PAGES IF NECESSARY. THE LINKS PROVIDE HELP AND GUIDANCE.

LINKS FOR SEATING THUMBNAIL SAMPLES



LINKS FOR SHADING TECHNIQUES



EXTENSION WORK

What you need to do:

MAKE A SIMPLE MODEL OF YOUR 'BEST' IDEA FOR THE PUBLIC SEATING
OR
PRODUCE A CAD DRAWING OF YOUR BEST IDEA.

